

WORLD CLASS · EFFICIENCY · RELIABILITY

k|r|s|p 2

TWO STAGE ROTARY



Kaishan Compressor USA

# WORLD WIDE SUPPORT

## Globally recognized industrial presence

Over the last sixty years, Kaishan has steadily grown to become a significant, diversified engineering company developing high value machinery for industries worldwide. With modern, specialized manufacturing facilities positioned in seven strategic locations, Kaishan's group of thirty-two subsidiary companies produce over 60,000

rotary screw and 250,000 reciprocating compressors annually. Kaishan is the world's third largest manufacturer of compressed air, mining and drilling equipment and supports industries in more than 60 countries including: USA, Australia, Germany, Japan, Korea, Russia, Africa and throughout Latin America.

## Vertically integrated global strategy

Kaishan's global strategy of combining highly skilled engineering with highly efficient manufacturing allows us to provide performance proven, reliable equipment at a significant cost savings to our customers. Additionally, Kaishan's manufacturing processes are 85% vertically

integrated insuring full control of the material supply chain. This vertical approach supplies high quality components at a lower cost, and affords Kaishan the ability to respond rapidly to changing market demands.



- 📍 Kaishan USA Headquarters & Manufacturing Facility - Mobile, AL
- 📍 Kaishan Subsidiary
- 📍 Kaishan Headquarters - Quzhou, China

## Practiced environmental sustainability

Integral to the design and manufacture of our products is outstanding energy efficiency. Kaishan's fundamental belief in environmental sustainability drives us to produce products that maximize energy efficiency and help to preserve precious energy resources. Single and two-stage compressors that produce more compressed air per unit of power input as well as expanders that utilize waste heat to produce electricity are just two of the fundamental products in our sustainable approach.

Throughout our manufacturing processes, unused waste materials are recycled at every stage to maximize the use of raw materials. This approach translates to lower initial costs and lower operating costs for our customers and a smaller environmental footprint that helps us all. Kaishan's commitment to environmental responsibility ensures that we will continue to develop technologies and manufacturing solutions that provide industry with machinery of exceptional value - now and well into the future.

## KRSP2 SERIES COMPRESSORS PROVIDE LOW CAPITAL COST AND LOW OPERATING COST

### Low cost of ownership throughout life cycle

Compressed air is often referred to as the 'fourth utility' and is critical to most manufacturing operations. Facility performance depends upon compressor reliability and efficiency.

Power consumption is a significant cost throughout the life cycle of a compressor. Therefore, it is important to consider the life cycle cost of a compressed air system when evaluating productivity improvements. KRSP2 series advanced energy saving features reduce operation costs significantly.



*KRSP2 Series 'best in class'  
rotor assembly*

**LIFETIME  
AIREND  
WARRANTY**

# WORLD CLASS ENGINEERING

## PATENTED 'SKY' TWO-STAGE AIR END DEVELOPED EXCLUSIVELY BY KAISHAN ENGINEERS

### Continued development has increased efficiency by more than 20% over earlier models

- **Two-Stage air end design** for high flow rate and low power consumption
- **Direct drive (through gears) motor and air end** operate at slow speed
- **Low part load energy consumption**
- **Steady system pressure** lowers system pressure fluctuation and overall air demand
- **Slow speed male rotors** maximize performance and increase reliability
- **Decreased energy consumption** reduces carbon footprint and delivers cost savings
- **5 / 6 rotor profile** creates optimal performance while reducing energy consumption
- **2 in 1 intake valve design** (with check valve) for increased efficiency
- **Direct flow inlet valve** provides reliable capacity control
- **Triplex SKF bearings** for durability and reliability
- **Very tight tolerances** provide maximum efficiency



*KRSP2 Series patented two stage air end*

## SAFETY AND THE ENVIRONMENT

### Reduced OSHA Risk and Injury

- The entire Kaishan range of compressors includes full safety features such as guarded rotating components and shrouded electrical components



## 'ULTRAWEB' AIR INTAKE FILTERS

### Increased Filtration Efficiency

- Full airflow, low restriction, nanofiber technology
- Deep bed media ensures excellent dust capture
- Increased free air delivery for further savings in energy and running costs

## SINGLE PASS OIL & AFTER COOLERS

### Long Life / Easily Accessible

- Minimize thermal stress
- Cooler running temperatures / correct running temperature @ 122F° (50°C) ambient capable
- Low oil carryover increases bearing life
- Low cooling air velocity reduces dust build up

## 3 STAGE TANGENTIAL OIL SEPARATION

### Lower Pressure Drop / Lower Absorbed Power

- Excellent oil mechanical pre-separation/ reduced direct oil impingement onto separator element
- Lower dust contact resulting in lower pressure drop / longer element life / lower energy consumption
- Residual oil carryover limited to 3 ppm

## TRIPLE DISCHARGE BEARINGS

### Longer Bearing Life / Quieter Operation

- The "SKY2" series air end uses three discharge bearings on the first stage and four bearings on the second stage
- Longest bearing life in the industry
- Warrantied for a "Lifetime" of use

## LAMINAR FLOW INLET VALVE

### Minimum Pressure Drop / Increased Output

- Laminar flow inlet valve results in lower pressure drop through the intake, increasing output and saving energy

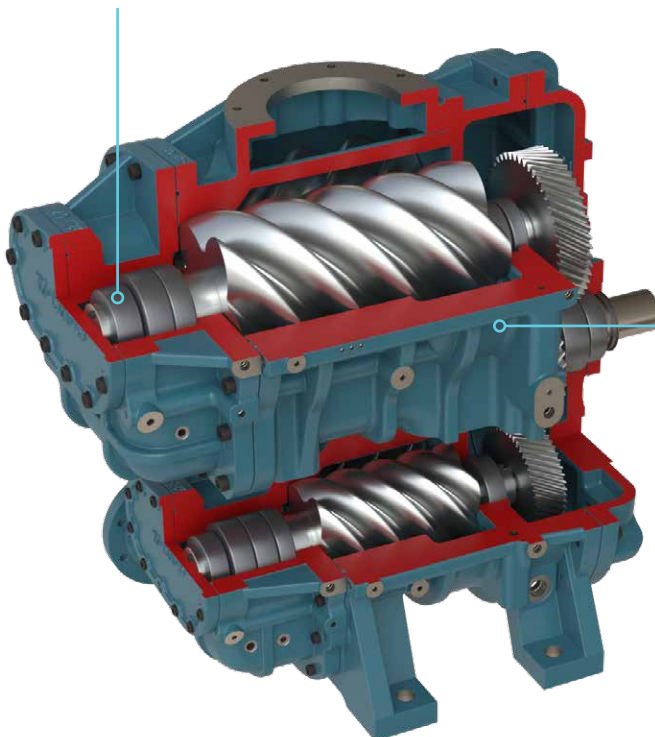
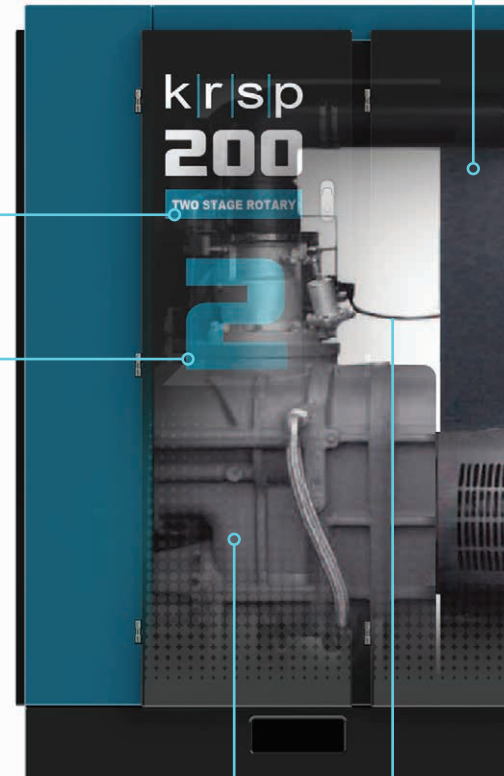

## 'SKY' SERIES AIR END

### Maximum Output with Less Energy Usage

- Asymmetric 5 / 6 rotor profile with 100% SKF bearings
- KAPP Grinder rotor technology for tighter clearances and world class efficiency and performance
- Precision machined bell housing to maintain rigid alignment

## CENTRIFUGAL COOLING FANS

### Increased Cooling Efficiency

- Higher static pressure allows for heat recovery ducting
- Even air flow across the cooler face.
- VSD cooling fan (150 HP and above) provides energy savings as cooling airflow is reduced during periods of light load or low temperatures
- Cooling air bypasses main compressor compartment resulting in minimal internal dust build up

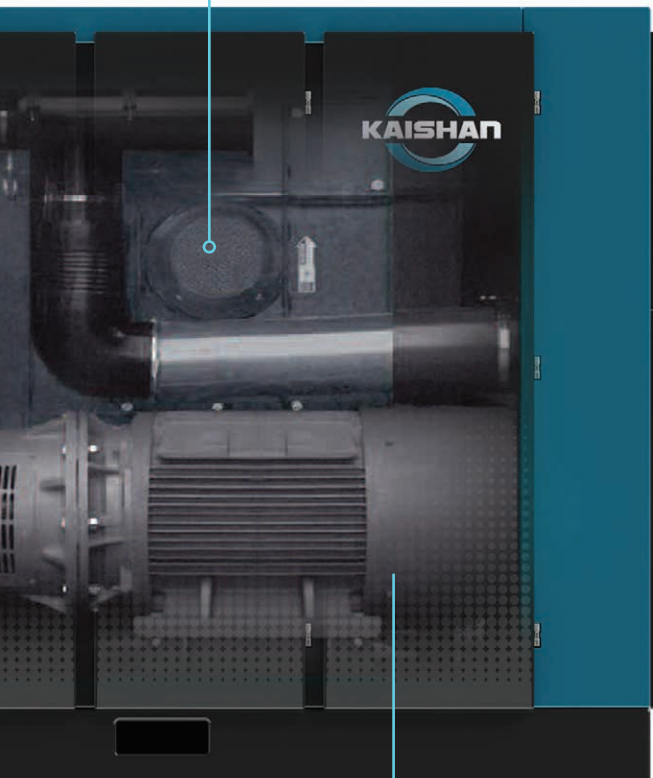

## DIGITAL CONTROL PANEL

### Monitors & Controls Key Compressor Functions

- Protects compressor in the event of a fault
- Provides service required alert
- Sequencing of up to 16 compressors
- External monitoring via RS 485 interface
- WYE Delta starter is standard on all models
- MODBUS capability



## INDUSTRIAL GRADE ELECTRICAL COMPONENTS

### Increased Reliability / Lower Servicing Cost

- Outstanding reliability
- Excellent component life
- Worldwide support
- Standard electrical parts available locally

## 316 STAINLESS STEEL CONTROL TUBING

### Long Tubing Life / Reduced Downtime

- Increased reliability due to corrosion free material
- Material such as nylon, copper or mild steel will fail in time causing downtime

## HIGH EFFICIENCY ELECTRIC MOTORS

### Long Operating Life / Lower Power Use

- Kaishan uses high efficiency motors, which comply with all international standards
- Motors are standard TEFC to IP 54 protection from dust and moisture
- Class F insulation
- Cooling air bypasses main compressor compartment resulting in lower component operating temperatures and longer life



# KRSP2 SERIES COMPRESSORS PROVIDE ROBUST, TURN-KEY INDUSTRIAL SOLUTIONS

**KRSP2 has low life cycle cost by providing:**  
**Low Capital Cost + Low Operating Cost + Exceptional Reliability & Efficiency**

- All electrical wiring is high performance including cable and converters
- Optimum operating temperature to prevent moisture in the system
- Rugged and proven technology to ensure long operating life
- Heavy duty isolators to minimize operating vibration
- SAE fittings greatly reduce oil leaks
- Spin-on fluid filter for quick maintenance
- VSD cooling fan on all units 150HP to 350HP
- Premium, efficient TEFC Electrical motors
- Acoustic enclosure brings the sound level to industry leading level of 67 dB(A) to 82 dB(A)

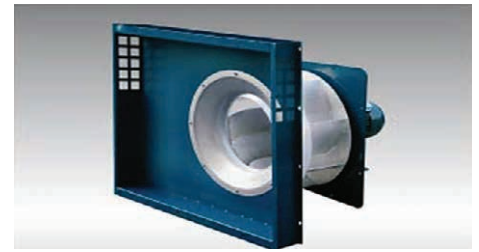

VSD cooling fan provides energy savings by reducing airflow during periods of light load or low temperatures.



Lubricant filter assembly features a spin-on, full-flow, 12µ, high-efficiency components

# KRSP2 SERIES VARIABLE SPEED DRIVE OPTION PROVIDES A MAJOR ENERGY SAVINGS

**KRSP2 VSD combines a robust power platform with a state-of-the-art control scheme**

The drive provides a soft start and the ability to operate efficiently through the compressor's capacity range by matching flow to demand, while maintaining a high level of pressure control. By eliminating wasted energy, cost savings as high as 35% or more are possible. With this level of savings, the additional capital cost of the variable speed drive can be recovered in less than one year's operation.

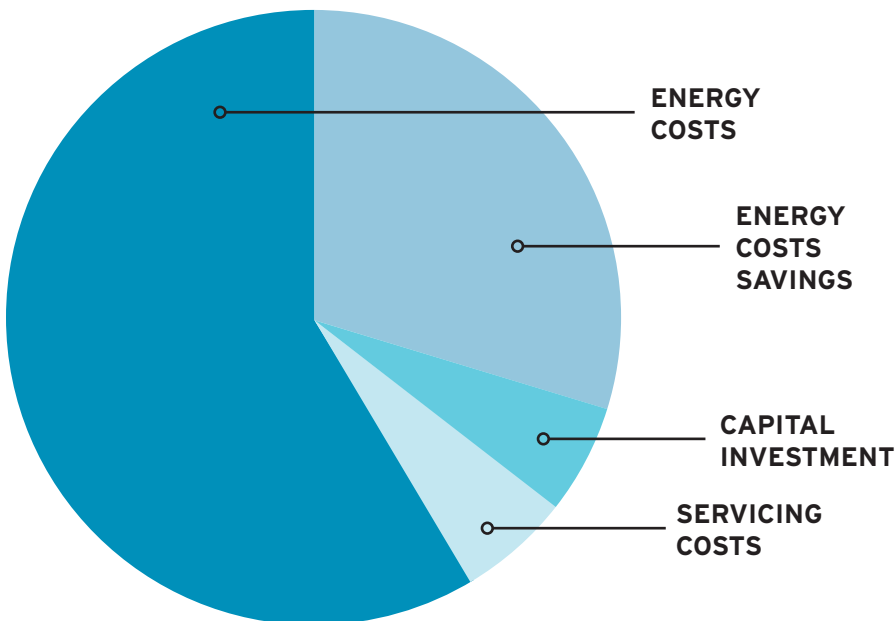

KRSP2 Variable Speed Drive

## Variable Speed Drive

The variable speed drive used in KRSP2 compressors are renowned for:

- Efficient and reliable service
- Worldwide support

KRSP2 Series VSD Rotary Screw Compressor operating at 70% load compared to a fixed speed model.

# KRSP2 SERIES CONTROL SYSTEM PROVIDES TOTAL MANAGEMENT OF ALL OPERATING PARAMETERS

## KRSP2 controller capabilities include the following features:

- Operating parameters display
- Programmed maintenance schedules
- Warning stop alarms
- Recordings of compressor history

The control panel contains a special programmed microprocessor that can safely and efficiently control all the functions of the compressor.

The touch screen display monitors line pressure, oil temperature and working conditions (running, idling and stop). Abnormal conditions will trigger a flashing LED and a flashing message indicating the cause for the alarm. Microprocessor functions are password protected, accessible only to authorized personnel.



KRSP2 series System Management Control Panel

## KRSP2 SERIES SPECIFICATIONS

MODEL KTA	CAPACITY CFM	POWER HP	FULL LOAD PSI	MAXIMUM PSI	SOUND dB(A)		DIMENSIONS (IN.)			WEIGHT (LB.)	
					AC	WC	L	W	H	AC	WC
KRSP2-100-100	600	100	100	110	72	N/A	101	64	76	7275	N/A
KRSP2-100-125	525	100	125	135	72	N/A	101	64	76	7275	N/A
KRSP2-125-100	739	125	100	110	72	72	101	64	76	7495	7495
KRSP2-125-125	669	125	125	135	72	72	101	64	76	7495	7495
KRSP2-125-150	599	125	150	160	72	72	101	64	76	7495	7495
KRSP2-150-100	873	150	100	110	73	73	122	70	81	10251	8598
KRSP2-150-125	738	150	125	135	73	73	122	70	81	10251	8598
KRSP2-150-150	667	150	150	160	73	73	122	70	81	10251	8598
KRSP2-200-100	1058	200	100	110	76	76	122	70	81	10582	8929
KRSP2-200-125	992	200	125	135	76	76	122	70	81	10582	8929
KRSP2-200-150	886	200	150	160	76	76	122	70	81	10582	8929
KRSP2-250-100	1455	250	100	110	75	75	136	76	89	14595	12346
KRSP2-250-125	1264	250	125	135	75	75	136	76	89	14595	12346
KRSP2-250-150	1169	250	150	160	75	75	136	76	89	14595	12346
KRSP2-300-100	1698	300	100	110	78	78	136	76	89	15102	13889
KRSP2-300-125	1618	300	125	135	78	78	136	76	89	15102	13889
KRSP2-300-150	1432	300	150	160	78	78	136	76	89	15102	13889
KRSP2-350-100	1998	350	100	110	80	80	152	85	94	20944	17747
KRSP2-350-125	1849	350	125	135	80	80	152	85	94	20944	17747
KRSP2-350-150	1677	350	150	160	80	80	152	85	94	20944	17747
KRSP2-400-100	2263	400	100	110	82	82	153	90	89	20393	19180
KRSP2-400-125	1960	400	125	135	82	82	153	90	89	20393	19180
KRSP2-400-150	1831	400	150	160	82	82	153	90	89	20393	19180
KRSP2-500-100	2641	500	100	110	82	82	153	90	89	21054	19290
KRSP2-500-125	2491	500	125	135	82	82	153	90	89	21054	19290
KRSP2-500-150	2322	500	150	160	82	82	153	90	89	21054	19290

Consult factory for higher pressure models. Performance test based on ISO 1217.



MODEL	COMPRESSOR TYPE	FEATURES
KRSP2	Two Stage	Global leader in air compressor efficiency
KRSP	Single Stage	Patented 'SKY' air end, triple SKF bearings
KRSD	Single Stage	Direct drive, TEFC motor, low sound enclosure
KRSB	Single Stage	Belt drive, economical to own and operate
KRST	Single Stage	Belt drive, tank mounted
KRSH	Two Stage High Pressure	Pressure to 580 PSI
KRSL	Single Stage Low Pressure	Pressure as low as 45 PSI
KRSV	Rotary Screw Vacuum Pump	World class vacuum efficiency



info@KaishanUSA.com

7650-A Staton Rd. · Daphne, AL 36526 USA

+1 251.202.0577

KaishanUSA.com